



बैंक नोट पेपर मिल इण्डिया प्रा. लिमिटेड

BANK NOTE PAPER MILL INDIA PVT LIMITED

JV of SPMCIL - A Govt. of India Enterprises & BRBNMPL - A Subsidiary of RBI

**BANK NOTE PAPER MILL INDIA PRIVATE LIMITED**

**CIN: U21090KA2010PTC055475**

**CORPORATE OFFICE, MYSORE**

**[gopalakrishnan.m@bnpmindia.com](mailto:gopalakrishnan.m@bnpmindia.com)**

**Ph: 0821 2401 158**

**Limited Tender Enquiry No: BNPM/LTE/SAFETY RING/431/2018-19**

**Issuing Date: 20.10.2018 12:00 hrs.**

**Closing date: 26.10.2018 15:00 hrs.**

**1. Scope of work:**

Supply of Safety Ring – GLT (as per drawing).

**2. Terms & Conditions:**

S. No	Particulars	Quantity
1.	Payment Terms	100% payment within 30 days of receipt and acceptance of goods by the consignee at destination and on production of all required documents by the supplier.
2.	Price	Price should be inclusive of all taxes & duties.
3.	Freight	Shall be included in quoted price.
4.	Packing & Forwarding	Shall be included in quoted price.
5.	Delivery Terms	D.A.P, Bank Note Paper Mill India Private Limited, Mysore
6.	Warranty Period	..... from date of supply at BNPM, Mysuru
7.	Warranty Certificate	Applicable / Not Applicable
8.	Delivery Period	2 samples to be submitted initially within 2 weeks for sample testing. On successful trials, remaining items to be delivered within 3 weeks from date of intimation.
9.	Material to be delivered at	Engineering Stores, Bank Note Paper Mill India Private Limited, Note Mudran Nagar, Mysore 570 003.
10.	Contact person	Mr. Gopalakrishnan M P: 0821-2401158



Drawing of Safety Ring:

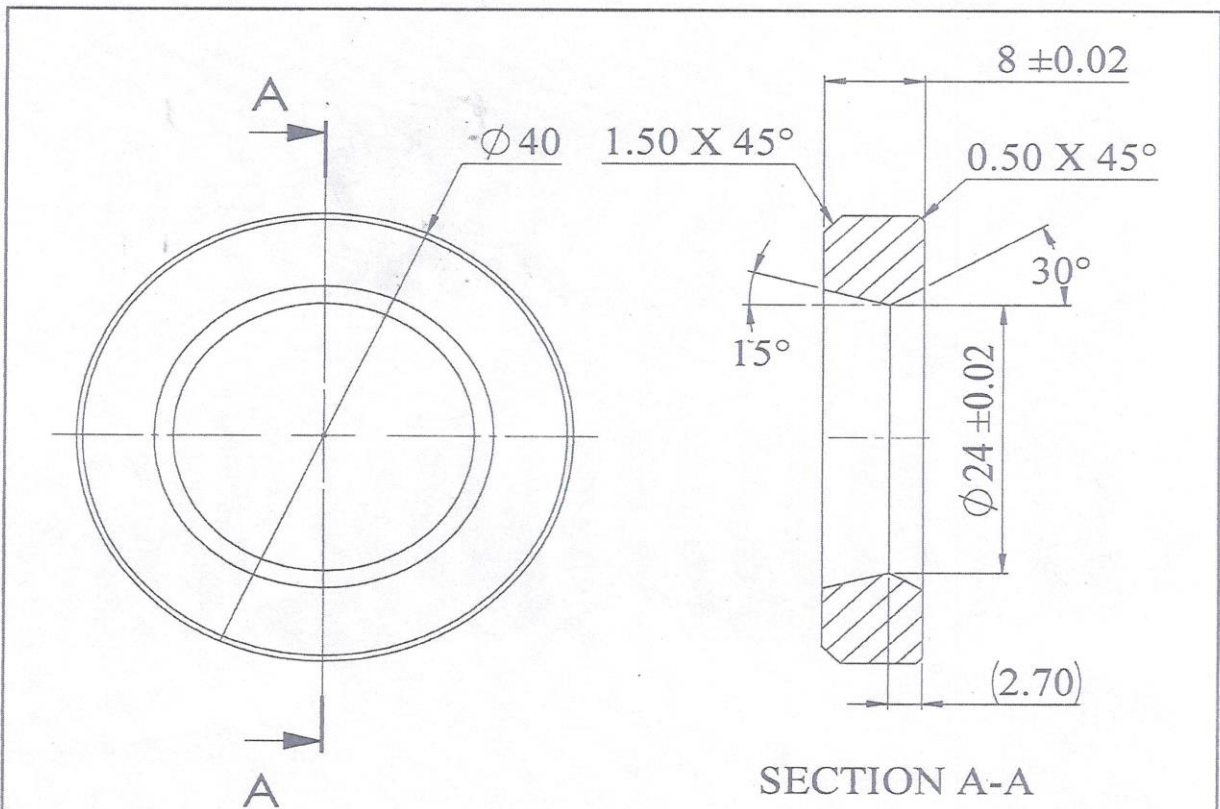

Note : All dimensions are in mm  
 Unspecified tolerance is +/- 0.1  
 General tolerance +/-0.15

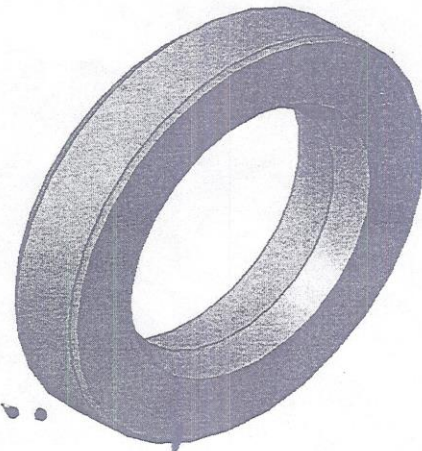

UNLESS OTHERWISE SPECIFIED DIMENSIONS ARE IN MILLIMETERS SURFACE FINISH: TOLERANCES: LINEAR ANGULAR		FINISH:	DEBUR AND BREAK SHARP EDGES	DO NOT SCALE DRAWING	REVISION
DRAWN	NAME	SIGNATURE	DATE	TITLE: <b>SAFETY RING</b>	
CHK'D	RODHAKRISHN	[Signature]	28-3-18		
APPV'D		[Signature]	RAKASH	MATERIAL: Carbon Steel - 45C8	
MFG					
QA				SCALE:2:1	SHEET 1 OF 1



**Limited Tender Enquiry No: BNPM/LTE/SAFETY RING/431/2018-19**

**Price Bid Format :**

S No	Description	Qty	UOM	Unit rate	Freight, P&F Charges	GST @ 18% (HSN - 8484)	Unit rate including GST & Freight, P&F Charges	Grand total inclusive of GST and Freight, P&F Charges (D.A.P, BNPM, Mysore)
1	Supply of Safety Ring - GLT (as per drawing)	10	Nos					
<b>Total price inclusive of all tax, freight , P&amp;F charges</b>								

**HSN Codes:** (8484)

We hereby confirm that

1. We accept all terms & conditions mentioned in the enquiry.
2. Price quoted is inclusive of all taxes, P&F, freight etc. on D.A.P, BNPM, Mysore basis.

Signature of bidder:.....

Name of the Firm:.....

Seal of the firm: .....

GST No: .....

